

Lubricity of materials and solutions

Summary

Coefficient of Friction (CoF) is used to quantify how readily two surfaces slide in the presence of a lubricant or oil. Conventional CoF tests use custom built hardware to measure the friction but no robust standardized approach is currently available and sensitivity and resolution are problematic. In conjunction with unique test geometries, commercial shear rheometers provide the sensitive force/displacement control that is required to measure CoF accurately and reproducibly. Understanding coefficient of friction can help in design of bearings and surface in industry and medicine.

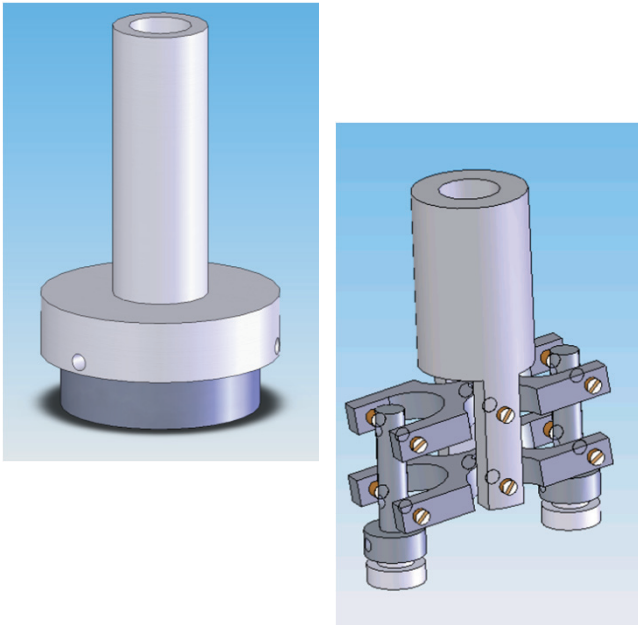

Description

The Coefficient of Friction determined using simple fixtures for commercial rheometers can be used to understand the performance of materials in biomedical and consumer applications. Often, apparently simple consumer observations such as “slimy” or “slippery” cannot be easily correlated with rheology, but are directly related to friction. In addition, the wear performance of biomedical materials and implants may be related to their apparent friction coefficient in the presence of physiological fluids. As a result, determination of CoF can allow insight into the sliding process in a vast array of applications. Two kinds of fixture can be used to provide the interaction between standard surfaces, or materials where only small amounts are available.

Data and outcomes

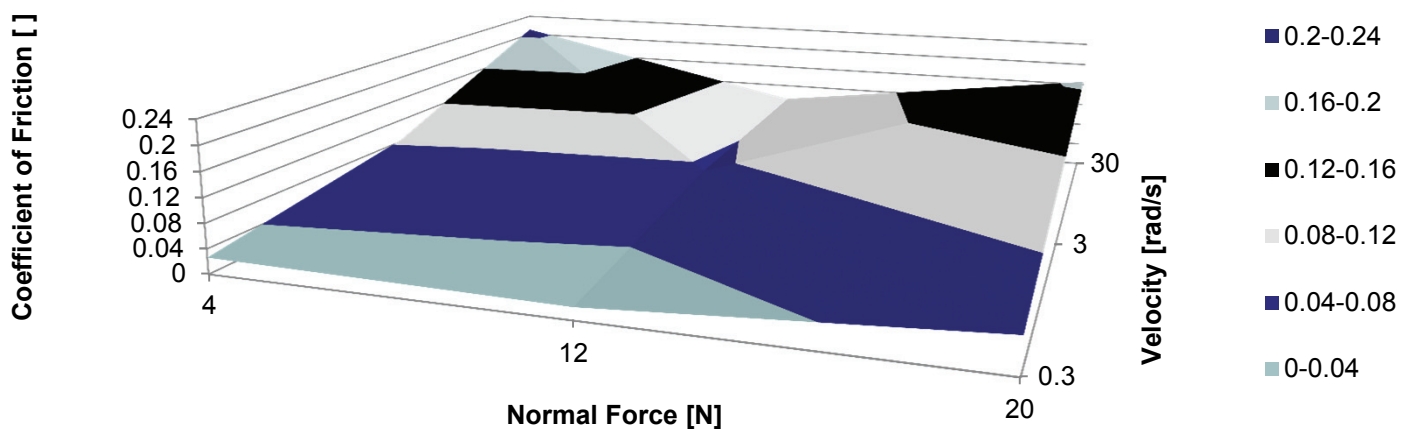

Uses

- Biomedical - Orthopedics
- Engineering
- Consumer products



**Cambridge
Polymer Group**

Cambridge Polymer Group, Inc.
56 Roland Street, Suite 310
Boston, MA 02129

Ph: 1 (617) 629 4400
Fax: 1 (617) 629 9100

info@campoly.com
www.campoly.com

ISO 9001:2008 Certified

Rev: 06/03/11

ANALYZE • RESEARCH • CREATE

Cambridge Polymer Group, Inc. is a contract research laboratory specializing in materials. We partner with our clients to solve problems utilizing our multi-disciplinary research team and full service laboratory.

We work with clients throughout the product life cycle to:

- **Develop new materials**
- **Design prototypes for proof-of-concept studies**
- **Create and execute experimental design**
- **Validate and verify manufacturing processes**
- **Perform root-cause analysis in product failures**

Cambridge Polymer Group, Inc. was founded in 1996 to provide a cost-effective resource for testing, research and development to clients who need periodic access to Ph.D.-level scientists and their support structure. We have developed a host of testing methods and materials for our clients, which number more than 300.



Cambridge
Polymer Group



Cambridge
Polymer Group

Cambridge Polymer Group, Inc.
56 Roland Street, Suite 310
Boston, MA 02129

Ph: 1 (617) 629 4400
Fax: 1 (617) 629 9100

info@campoly.com
www.campoly.com
ISO 9001:2008 Certified

Rev: 06/03/11